

Type 100 Series Threaded Capsule Diaphragm Seal



TYPE 100 SHOWN

When isolation of the process from an instrument is required, Ashcroft® offers a comprehensive line of diaphragm seals. Seal types include threaded, flanged, in-line threaded, in-line flanged, in-line socket weld, in-line butt weld, saddle and sanitary seals. Also available is a complete offering of isolation or iso-rings and isolation or iso-spools.

APPLICATIONS

- Elevated process temperatures
- Corrosive service
- Isolation of the process for safety
- Suspended solids in the process
- Sanitary connections
- Minimize process dead leg
- Ease of cleaning between batches

FEATURES

- The top housing and diaphragm capsule are interchangeable with all Ashcroft bottom housings.
- A fill/bleed connection is standard, which permits filling the seal and instrument simultaneously after evacuation and allows the fill to flow into the completed unit.
- A Viton O-ring, compatible with all standard fill fluids, and a Teflon back-up ring provide a seal between the diaphragm capsule and the top housing.
- A thin Teflon PTFE gasket between the diaphragm and bottom housing ensures a leak-tight corrosion resistant seal even at high pressure.
- Top housing and pressure instrument are removable.
- Continuous-duty design will prevent loss of process fluid if pressure instrument is removed or fails.

SPECIFICATIONS

Model Number: Type 100, 101, 102, 103, 104, 105, 106, 107, 108

Process Connection Size: See Table A (Pg. 2)

Instrument Connection Size: ¼, ½ NPT

Diaphragm Material: See Table B (Pg. 2)

Bottom Housing Materials: See Table C (Pg. 2)

Filling Fluid: Glycerin, Halocarbon, Silicone, Stylytherm

OPTIONS

| | Code |
|---|-------------|
| 316 stainless steel top housing | YT |
| Stainless steel clamp rings and flanged ring – includes 300 stainless steel clamping bolts (1500 psi max) | SE |
| 300 series stainless steel clamping bolts (max pres is 1500 psi) | SB |
| Pipe plugs for flushing connections – pipe plugs are available in the same materials as bottom housings per Table C (Pg. 2) | PU |
| 5000 psi pressure rating Threaded inlet and metal diaphragm only | HP |
| Welded instrument to diaphragm seal | DU |
| Dual flushing connections (½ NPT) (Limited to 2" thru 3" flanged seals) | DB |
| Ring joint (Flanged seal only) | RJ |
| Flat face (Flanged seal only) | FF |
| Clean for gaseous oxygen or strong oxidizing agent applications | 6B |

Type 100 Series Threaded Capsule Diaphragm Seal

TYPE 100 SERIES THREADED CAPSULE SEAL TYPES

Type 100 – Threaded
¼, ½, ¾, 1 NPT



Type 101 – Threaded
with flushing connection
¼, ½, ¾, 1 NPT



Type 102 – Raised Face Flanged
½, ¾, 1, 1½, 2, 3"



Type 103 – Raised Face Flanged
½, ¾, 1, 1½, 2, 3
with flushing connection



Type 104 – In-line Threaded
¼, ½, ¾, 1 NPT



Type 105 – Saddle
3, 4" pipe only



Type 106 – In-line Flanged
½, ¾, 1, 1½, 2, 3, 4, 6, 8"



Type 107 – In-line Socket Weld
½, ¾, 1, 1½, 2"



Type 108 – In-line Butt Weld
¼, ½, ¾, 1, 1½, 2"



Table A – Process Connection/Type Number

| Process Connection | Size Code | Process Connection Size/Code—Inches | | | | | | | | | | Type Number |
|---|-----------|-------------------------------------|----|----|----|----|----|----|------------|----|---|-------------|
| | | ¼ | ½ | ¾ | 1 | 1½ | 2 | 3 | 4 | 6 | 8 | |
| Threaded—female NPT | 25 | 50 | 75 | 10 | 15 | 20 | 30 | 40 | 60 | 80 | | 100 |
| Threaded—female NPT (with flushing conn.) | | | | | | | | | | | | 101 |
| Flanged ⁽¹⁾ | | | | | | | | | | | | 102 |
| Flanged (with flushing conn.) | | | | | | | | | | | | 103 |
| In-line—threaded NPT | | | | | | | | | | | | 104 |
| Saddle | | | | | | | | | AND LARGER | | | 105 |
| In-line—butt weld | | | | | | | | | | | | 108 |
| In-line—flanged ⁽²⁾ | | | | | | | | | | | | 106 |
| In-line—socket weld | | | | | | | | | | | | 107 |

Pressure Ratings—All 2500 psi except flanged seals are per ASME B 16.5, temperature limit determined by diaphragm, bottom housing and/or filling fluid.

Table B – Diaphragm Material

| Material | Code |
|--------------------------------|------|
| 316L stainless steel | S |
| 304L stainless steel | C |
| Monel 400 | P |
| Nickel | N |
| Carpenter 20 | D |
| Tantalum | U |
| Hastelloy B | G |
| Hastelloy C 22 ⁽³⁾ | J |
| Hastelloy C 276 ⁽³⁾ | H |
| Halar Coated Monel | R |
| Gold Plated 304 SS | W |

Table C – Housing Materials

| Bottom | Code |
|-------------------------------------|------|
| Steel | B |
| 304L SS | C |
| 316L SS | S |
| Hastelloy B | G |
| Hastelloy C 22 ⁽³⁾ | J |
| Hastelloy C 276 ⁽³⁾ | H |
| Carpenter 20 | D |
| Monel "400" | M |
| Inconel "600" | W |
| Nickel | N |
| PVC ⁽⁴⁾⁽⁹⁾ | V |
| Tantalum clad SS ⁽⁵⁾ | SU |
| Halar coated SS ⁽⁶⁾ | BH |
| Teflon flanged steel ⁽⁷⁾ | T |
| Kynar ⁽⁸⁾⁽⁹⁾ | KY |
| Titanium | TI |

Table D – Instrument Connection

| Size – NPT | Code |
|------------|------|
| ¼ | O2T |
| ½ | O4T |

Table E – Filling Fluid

| Filling | Service | Connection to Instrument | Temperature Range °F | Code |
|------------|---|--------------------------|----------------------|------|
| Glycerin | Pressure | Direct Only | 0/400 | CG |
| Silicone | Pressure/Vacuum | Direct or Flexible Line | -40/600 | CK |
| Halocarbon | Pressure/Vacuum in presence of strong oxidizing agent | Direct or Flexible Line | -70/300 | CF |
| Syltherm | Pressure/Vacuum | Direct or Flexible Line | -40/750 | HA |

Notes:

- (1) 150, 300, 600, 900, 1500 & 2500 class flanges.
- (2) 1" 150 thru 8" 300 class flanges only.
- (3) Use on applications where NACE standard MR-01-75/ISO 1516 w/Sept. 2005 corrigendums.
- (4) Maximum Press./Temp.
Threaded: 200 psi/74°F, 125 psi/125°F, 80 psi/150°F.
Flanged: 75 psi/100°F.
- (5) Type 102 only.
- (6) Type 102 only – Temp. Limits: -40/300°F.
- (7) Only available in 1", 1½", & 2" 150 class, Types 102.
Max. Press./Temp. – 270 psi and 150°F. Consult factory for conditions beyond these limits.
- (8) Maximum Pressure/Temp.: 200 psi and 180°F.
- (9) Type 100: ¼ or ½ NPT only. Larger sizes offered with solvent weld joint. N/A in 101 or 103 design.

Monel is a registered trademark of Huntington Alloys, Inc.
Hastelloy is a registered trademark of Cabot Corp.
Halocarbon is a registered trademark of Halocarbon Products
GYLON 3510 is a registered trademark of Garlock Inc.

HOW TO ORDER:

- From Table A...select TYPE NUMBER based on process connection, process connection size and diaphragm type/construction. (e.g., Threaded/1"capsule-code-10-100)
- From Table B...select DIAPHRAGM MATERIAL. (e.g., 316L stainless steel-code S)
- From Table C...select BOTTOM HOUSING MATERIAL. (e.g., 316 stainless steel-code S)
- From Table D...select INSTRUMENT CONNECTION size. (e.g., ¼ NPT-code O2T)
- From Table E...select FILLING FLUID, if diaphragm seal will be attached to instrument. (e.g., Glycerin-code CG)

Typical code: 10-100SS-O2T-CG

Type 100 Series Threaded Capsule Diaphragm Seal

DIMENSIONS

Type 100 – Threaded

¼, ½, ¾, 1 NPT

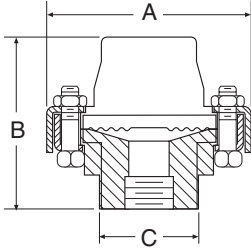

| A | | B | | C | |
|----|------|----|------|----|------|
| in | mm | in | mm | in | mm |
| ¾ | (95) | 2⅞ | (73) | 1⅞ | (46) |

Type 102 – Flanged 1" (raised face only)

one piece bottom housing, with and without flushing connection

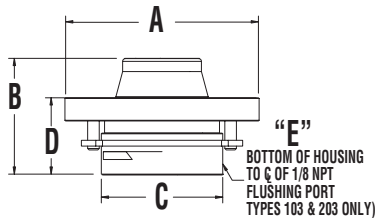

| Flange | | A | | B | | C | |
|--------|-------------------|------------|----------------|--------|------|---------|------|
| Size | Rating # | in | mm | in | mm | in | mm |
| 1 | 150 300 or 600 | 4-1/4 5 | (100) (127) | 2-9/16 | (65) | 1-23/32 | (69) |

| Flange | | 103 & 203 only | | | |
|--------|-------------------|----------------|------|-----|-----|
| Size | Rating # | D | E | | |
| | | in | mm | | |
| 1 | 150 300 or 600 | 1-5/8 | (41) | 3/8 | (9) |

Type 102 – Flanged 1" (raised face only)

two piece bottom housing, 1½, 2, - PVC, Teflon and Kynar

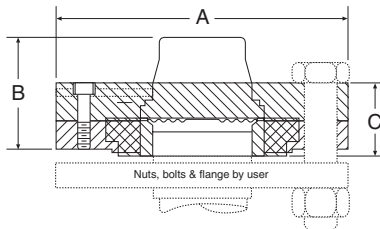

| Flange | | A | | B | | C | |
|--------|----------|----|-------|----|------|----|------|
| Size | Rating # | in | mm | in | mm | in | mm |
| 1½" | 150 | 5 | (127) | 2⅞ | (59) | 1⅞ | (39) |
| 2" | 150 | 6 | (152) | 2½ | (54) | 1⅞ | (40) |

Type 101 – Threaded

¼, ½, ¾, 1 NPT (with flushing connection)

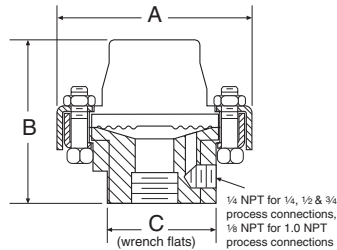

| A | | B | | C | |
|----|------|----|------|----|------|
| in | mm | in | mm | in | mm |
| ¾ | (95) | 2⅞ | (73) | 1⅞ | (46) |

Type 102 – Flanged 1" (raised face only)

one piece bottom housing, with and without flushing connection

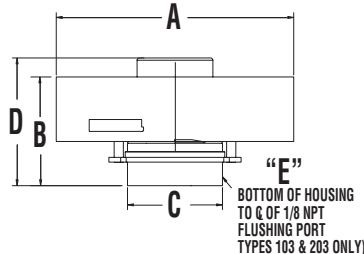

| Flange | | A | | B | | C | |
|--------|---------------------|----------------|----------------|-------|------|-------|------|
| Size | Rating # | in | mm | in | mm | in | mm |
| 1 | 900 or 1500 2500 | 5-7/8 6-1/4 | (149) (159) | 2-7/8 | (73) | 2-1/4 | (57) |

| Flange | | 103 & 203 only | | | |
|--------|---------------------|----------------|------|-----|-----|
| Size | Rating # | D | E | | |
| | | in | mm | | |
| 1 | 900 or 1500 2500 | 3-3/8 | (86) | 3/8 | (9) |

Type 103 – Flanged

½, ¾" (with flushing connection)

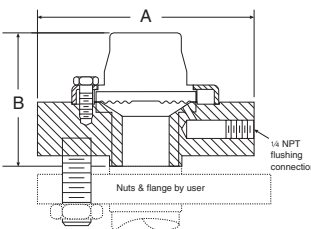

| Flange | | A | | B | |
|-------------|------------|----|-------|----|------|
| Size | Rating # | in | mm | in | mm |
| 150 | | 3½ | (89) | 2⅞ | (75) |
| ½" | 300 or 600 | 3¾ | (95) | 3 | (76) |
| 900 or 1500 | | 4¾ | (121) | 3⅞ | (81) |
| 150 | | 3⅞ | (98) | 2⅞ | (71) |
| ¾" | 300 or 600 | 4¾ | (117) | 3 | (76) |

Type 102 – Flanged

½, ¾"

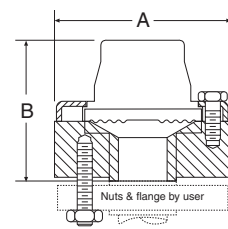

| Flange | | A | | B | |
|-------------|------------|----|-------|----|------|
| Size | Rating # | in | mm | in | mm |
| 150 | | 3½ | (89) | 2⅞ | (75) |
| ½" | 300 or 600 | 3¾ | (95) | 3 | (76) |
| 900 or 1500 | | 4¾ | (121) | 3⅞ | (81) |
| 150 | | 3⅞ | (98) | 2⅞ | (71) |
| ¾" | 300 or 600 | 4¾ | (117) | 3 | (76) |
| 900 or 1500 | | 5½ | (130) | 3⅞ | (81) |

Type 102 – Flanged (raised face only)

1½, 2, 3" one piece bottom housing - all materials except PVC, Teflon and Kynar

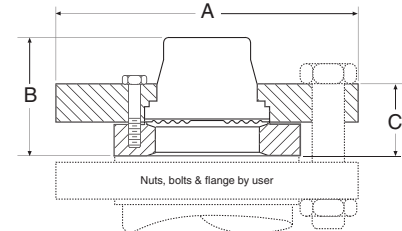

| Flange | | A | | B | | C | |
|-------------|------------|-----|-------|----|------|----|------|
| Size | Rating # | in | mm | in | mm | in | mm |
| 150 | | 5 | (127) | | | 1½ | (38) |
| 1½" | 300 or 600 | 6¼ | (159) | 2⅞ | (61) | 1½ | (38) |
| 900 or 1500 | | 7 | (178) | | | 1½ | (38) |
| 150 | | 6 | (152) | | | 1¾ | (35) |
| 2" | 300 or 600 | 6½ | (165) | 1⅞ | (49) | 1½ | (38) |
| 900 or 1500 | | 8½ | (216) | | | 2½ | (54) |
| 150 | | 7½ | (191) | 2 | (51) | 1¾ | (41) |
| 3" | 300 or 600 | 8¼ | (206) | 2⅞ | (52) | 1⅞ | (47) |
| 900 or 1500 | | 10½ | (267) | 2⅞ | (68) | 3¼ | (82) |

Type 100 Series Threaded Capsule Diaphragm Seal

DIMENSIONS

Type 103 – Flanged 1½", 2", 3" (raised face only)
 one piece bottom housing with flushing connection

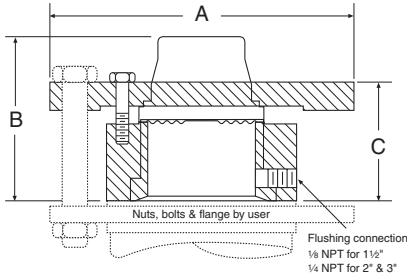

| Flange Size | Rating # | A in | A mm | B in | B mm | C in | C mm |
|-------------|-------------|------|-------|------|------|------|------|
| 150 | | 5 | (127) | | | | |
| 1½" | 300 or 600 | 6¼ | (159) | 3 | (76) | 2½ | (64) |
| | 900 or 1500 | 7 | (178) | | | | |
| 2" | 150 | 6 | (152) | | | | |
| | 300 or 600 | 6½ | (165) | 3½ | (89) | 2¾ | (71) |
| | 900 or 1500 | 8½ | (215) | | | | |
| 3" | 150 | 7½ | (191) | 3¾ | (94) | 2¾ | (71) |
| | 300 or 600 | 8¼ | (210) | 3¾ | (94) | 2¾ | (71) |
| | 900 | 9½ | (241) | | | | |
| | 1500 | 10½ | (267) | | | | |

Type 105 – Saddle
 4" Pipe only

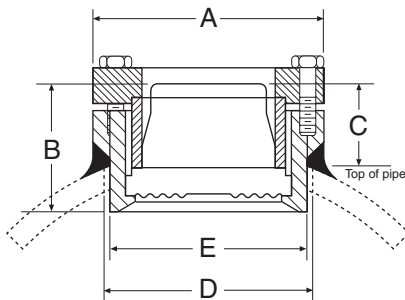

| A in | A mm | B in | B mm | C in | C mm | D in | D mm | E in | E mm |
|------|------|------|------|------|------|------|------|------|------|
| 3½ | (89) | 1½ | (50) | 1¾ | (31) | 3 | (76) | 2¾ | (71) |

Type 104 – In-Line Threaded
 ¼, ½, ¾, 1 NPT

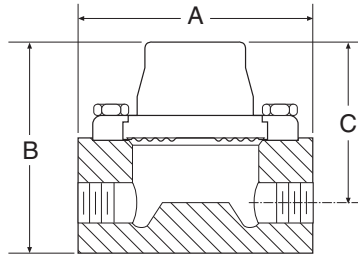

| Process Connection | A in | A mm | B in | B mm | C in | C mm |
|--------------------|------|-------|------|------|------|------|
| ¼ NPT | | | 2½ | (67) | 2½ | (64) |
| ½ NPT | 4 | (102) | 3¾ | (92) | 2¾ | (71) |
| ¾ NPT | | | 3¾ | (98) | 3 | (76) |
| 1 NPT | | | 3¾ | (98) | 3 | (76) |

Type 106 – In-Line Flanged
 ½", 1", 1½", 2", 3"

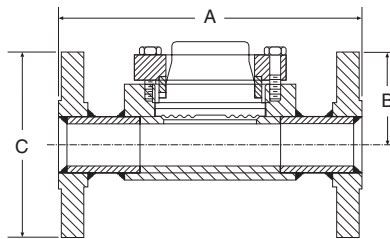

| Flange Size | Rating # | A in | A mm | B in | B mm | C in | C mm |
|-------------|----------|------|-------|------|------|------|-------|
| 150 | | 7 | (178) | | | | |
| ½" | 300 | 7 | (178) | 2¾ | (67) | 3½ | (89) |
| | | | | | | 3¾ | (92) |
| 1" | 150 | 7 | (178) | 2¾ | (67) | 4¼ | (108) |
| | 300 | 8 | (203) | | | 4¾ | (123) |
| 1½" | 150 | 8 | (203) | 2½ | (67) | 5 | (127) |
| | 300 | 9 | (229) | | | 6½ | (165) |
| 2" | 150 | 9 | (229) | 2½ | (67) | 6 | (152) |
| | 300 | 10 | (254) | | | 6½ | (165) |
| 3" | 150 | 11 | (279) | 3¾ | (92) | 7½ | (191) |
| | 300 | 12 | (305) | | | 8¼ | (210) |

Type 105 – Saddle
 3" Pipe only

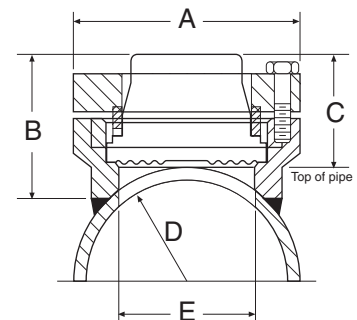

| A in | A mm | B in | B mm | C in | C mm | D in | D mm | E in | E mm |
|------|------|------|------|------|------|------|------|------|------|
| 3½ | (89) | 2¼ | (57) | 1¾ | (48) | 1¾ | (44) | 2½ | (64) |

Type 106 – In-Line Flanged
 4", 6", 8"

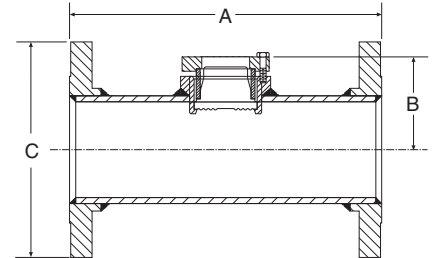

| Flange Size | Rating # | A in | A mm | B in | B mm | C in | C mm |
|-------------|----------|------|-------|------|-------|------|-------|
| 150 | | 13 | (330) | | | | |
| 4" | 300 | 14 | (356) | 3¾ | (86) | 9 | (229) |
| | | | | | | 10 | (254) |
| 6" | 150 | 16 | (406) | 4¾ | (113) | 11 | (279) |
| | 300 | 17 | (432) | | | 12½ | (318) |
| 8" | 150 | 16 | (406) | 5¾ | (138) | 13½ | (343) |

Type 107 – In-Line Welded
 ¼", ½", ¾", 1", 1½", 2"

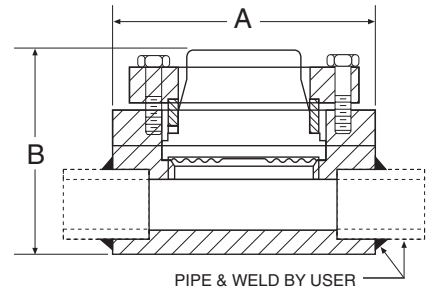

| Pipe Size | A in | A mm | B in | B mm |
|-----------|------|-------|------|------|
| ¼" | | | 2½ | (60) |
| ½", ¾" | | | 2½ | (60) |
| 1" | | | 2½ | (60) |
| 1½" | 4 | (102) | 2¾ | (67) |
| 2" | | | 2¾ | (67) |