



3 PC Full Port Ball Valves

Flo-Tite's Unique...
MULTI-CHOICE SERIES

1500 WOG size 1/4"-2 1/2"
1250 WOG size 3" - 4"

Models:

300 - (316SS)

200 - (WCB)



SIZE 1/4" - 2 1/2"
 Optional 6" thru 12"

Weld-in-Place Technology
 Heat Diffusion Design

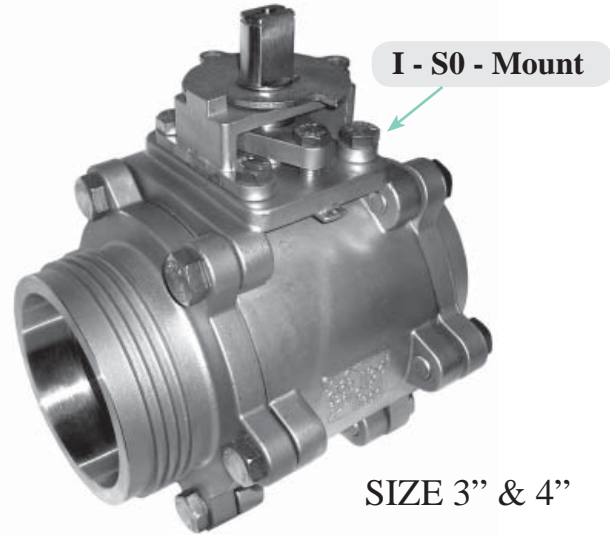

SIZE 3" & 4"

Shown with Optional
 Weld-In-Place Ends

SPECIAL FEATURES

- I-SO-MOUNT TYPE AUTOMATION PAD
- WELD IN PLACE DESIGN
- SECONDARY MEDIA CONTAINMENT
- LIVE-LOADED STEM ASSEMBLIES
- SWING-OUT BODY DESIGN
- SAFETY LOCKING HANDLE
- ANTI-STATIC GROUNDING DEVICE
- SUPER-TEK-SEATS, STANDARD
- SECONDARY METAL SEAT OPTION
- CAVITY FILLER - ALL SIZES OPTION
- METAL NAME PLATES IDENTIFY ALL SOFT PARTS

END CAP SELECTION

- THREADED (NPT)
 - SOCKET WELD
 - BUTT WELD
 - ANSI 150/300 FLANGED CONNECTIONS
 - TRI CLAMP-SANITARY END
 - GROOVED ENDS
 - TUBE END
 - FLUSH BOTTOM TANK
 - EXTENDED END SW
 - EXTENDED END B/W
- V-Port Control Valve Characterized
 Ball V15°, V30°, V60°, V90°*

UNIQUE DESIGN

- **SIZE Range**
 1/4" thru 4"
 Optional 6"~12"
- **1500 WOG/150 WSP**
 1/4" ~ 2-1/2",
 1250 WOG/150 WSP
 3" - 4"
 ANSI 150/300 6"~12"
- **CAP SCREWS** are used to insure precise alignment of valve center body to end caps. This high-end design feature eliminates through bolts, nuts, washer and their related problems.

*Unique 3PC Design Serves As Both Valve And Union
 Thus Eliminating Costly And Heavy Flanges!*

DESIGN & TECHNICAL DATA

Model Numbers:

End Connections:

STAINLESS	CARBON	CONNECTIONS:
310	210	THREADED END
320	220	SOCKET WELD
330	230	BUTT WELD
340	240	150 LB. FLANGE
350	250	TRI CLAMP-SANITARY END
360	260	CAM LOCK
370	270	TUBE END
395	395	EXTENDED END B/W
390	290	GROVED END
TK300	TK200	FLUSH BOTTOM TANK

Any combination of above end connections are available C/F.

Consult Ball Valve Identification Code Guide for Full Part Number, Tech Bulletin page 188

SPECIFICATION STANDARDS:

- Threaded End, ANSI B1.20.1 NPT
- Socket Weld, ANSI B16.11
- Butt Weld MSS SP72
- Meets WW-V35C Type II
Composition: SS Style
- Shell Wall ANSI B16.34
- Flanged End Class 150 or 300
- Valve Body and Caps are high quality investment castings
- NACE MR-01.75 compliant
- ISO 5211 Mounting Pad

RATINGS:

- Pressure Rating:
Threaded, Socket Weld
Butt Weld schedules 5, 10, & 40
Size 1/4" thru 4" - 1500 WOG
Size 6" and larger Butt Weld, Socket Weld,
Threaded End - 800 WOG
- Flanged End ANSI 150/300
- Steam Rating: 150 PSI WSP
250 PSI steam rated valves are available with Super-Tek III seats
- Vacuum service to 20 microns

All Valves Tested to MSS SP-72 at 100 psi under Water in Open and Closed Positions

Exploded View For 1/4"~2-1/2"

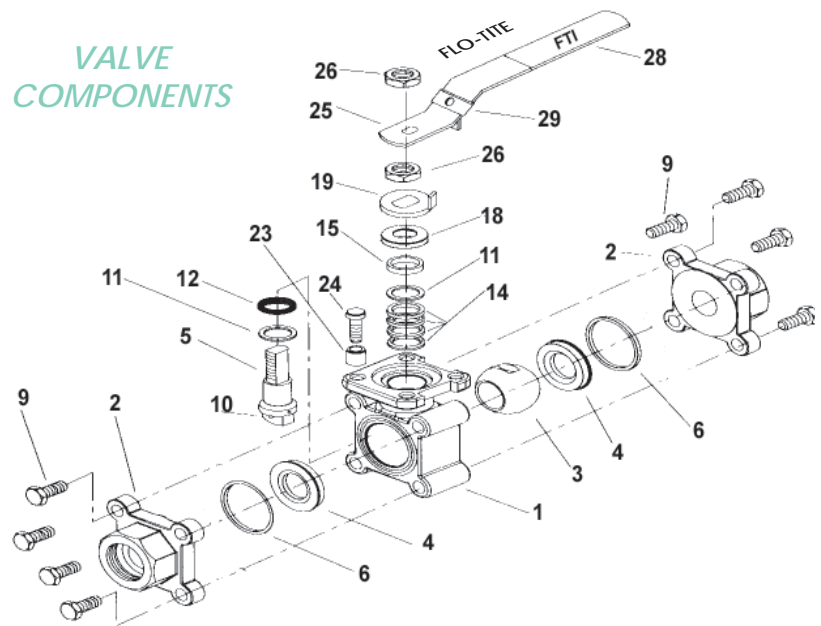

UNIQUE FEATURES

Ball Design Added Safety Feature:

As an added safety feature, there is a hole in the stem slot of each ball to equalize pressure between the body cavity and the flow stream when valve is in the open position.

Relief Holes in Seats Relieve Pressure Past the Upstream Seat.

Flo-Tite's

safety lockable handle designed to prevent accidental movement.



The valve can also be padlocked to limit unwanted access.



Flo-Tite's QUALITY CONTROL INCLUDES:

- ✓✓ All castings go through spectroscopic analysis
- ✓✓ Microstructure test after solution heat treating
- ✓✓ Inspection of appearance after shot blasting

- ✓✓ Size/dimension gauge test after CNC machining
- ✓✓ Final air pressure leakage test at 100 PSI under water in Open and Closed positions.

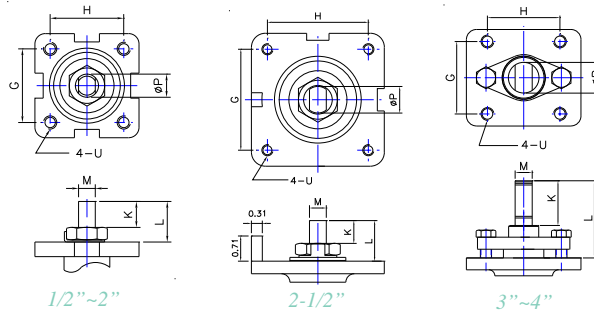
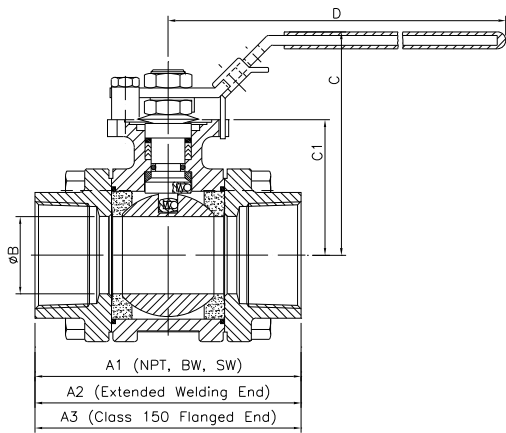

NOTE: Verify the mounting dimensions before manufacturing actuator mounting hardware.

Size	G	H	L	K	M	P	U
1/2", 3/4"	1.169	1.169	0.55	0.32	0.250	0.38	#10-24unc
1", 1 1/4"	1.392	1.392	0.75	0.43	0.315	0.44	1/4-20unc
1 1/2", 2"	1.949	1.949	0.91	0.55	0.374	0.63	5/16-18unc
2-1/2"	2.840	2.840	1.14	0.69	0.472	0.75	5/16-18unc
3", 4"	2.840	2.840	3.07	1.75	0.669	1.10	1/2-13unc

BILL OF MATERIALS: Size 1/4" thru 4" inch

No.	Part Name	300 Series Stainless Steel	200 Series Carbon Steel	Qty
1	Body	ASTM A351 CF8M - 316	ASTM A216 Gr. WCB	1
2	End Cap Connector	ASTM A 351 CF8M @	ASTM A216 Gr. WCB	2
3	Ball	ASTM A351 CF8M - 316	ASTM A351 CF8M - 316	1
4	Seat *	Super-Tek TFM or RTFE	Super-Tek TFM or RTFE	2
5	Stem	ASTM A276 Type 316	ASTM A276 Type 316	1
6	Body Seal *	Super-Tek TFM or RTFE	Super-Tek TFM or RTFE	2
9	Body Bolt	SS304 / ASTM A193 B8	SS304 / ASTM A193 B7	8 / 12
10	Anti-Static	SS316	SS316	2
11	Thrust Bearing *	25% Carbon TFM	25% Carbon TFM	1
12	Guide Seal * #	Viton O-Ring (C/F for other options)	Viton O-Ring (C/F for other options)	1
14	Stem Packing	Super-Tek TFM or RTFE	Super-Tek TFM or RTFE	3
15	Packing Follower	SS304	SS304	1
18	Belleville Washer	SS301	SS301	2
19	Lock Washer	SS304	SS304	1
23	Valve Stop - Set Sleeve	SS304	SS304	1
24	Valve Stop - Bolt	SS304	SS304	1
25	Lever Handle	SS304	SS304	1
26	Thin Nut	SS304	SS304	2
28	Lever Sleeve	Plastic	Plastic	1
29	Locking Device	SS304	SS304	1

* Recommended Spare Parts (Consult factory for B8 and B7 bolting) @ Weld Ends use CF8M-316L # Check media compatibility

DIMENSIONS, TORQUES, AND WEIGHTS:

Size	A1	A2	A3	B	C1	C	D	Weight (lbs)	Torque (in-lbs)	Cv
1/4", 3/8", 1/2"	2.84	5.57	4.39	0.59	1.54	2.60	6.50	2.1	50	18
3/4"	3.35	6.06	5.80	0.79	1.66	2.91	6.50	2.4	70	42
1"	3.62	6.32	5.97	0.98	2.05	3.43	7.87	3.5	95	74
1-1/4"	4.33	c/f	-	1.26	2.21	3.62	7.87	5.1	190	130
1-1/2"	4.84	6.94	8.03	1.50	2.60	4.13	9.84	8.0	200	210
2"	5.59	7.76	9.04	2.00	2.95	4.53	9.84	12.0	340	380
2-1/2"	7.26	c/f	-	2.56	3.39	5.04	9.84	22.0	480	645
3"	7.95	9.45	10.10	2.99	3.72	6.42	15.35	32.5	780	890
4"	9.06	10.56	13.90	4.02	4.35	7.09	15.35	56.0	1600	1620
6"	18.0	c/f	15.50	5.98	7.17	12.20	43.30	204	4600	5000

PRESSURE & TEMPERATURE DATA

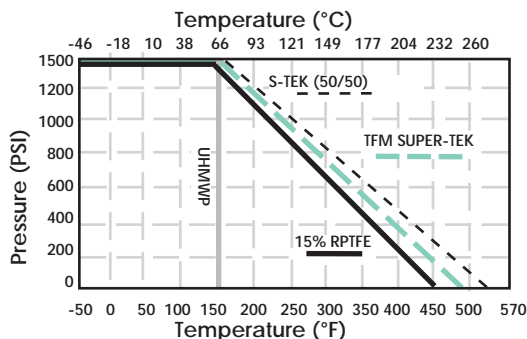

OPTIONAL SEAT MATERIALS

- UHMWP-Ultra High Molecular Weight Polyethylene
- Carbon Filled Teflon
- Bronze Filled Teflon
- Stainless Teflon
- Virgin Teflon
- Peek
- Stellite-Metal
- Super-Tek (TFM)
- Super-Tek III (Carbon/TFM)
- Cavity Fillers

* Carbon Steel Bodies are Black Phosphate Coated for Added Corrosion Resistance

* All Carbon Body Valves Have Stainless Steel Hardware

Flo-Tite's Van Guard stem sealing system, designed to minimize fugitive emissions. Increases safety and provides an immediate ball valve solution to the newer EPA performance requirements, for valves meeting with a leak rate of 500ppm.

Flo-Tite's Van Guard seal, state of the art stem sealing system. Incorporating a triple set of valve stem seals. This unique system eliminates the possibility of valve stem leaks in most all media applications.

STAGE I - FRONT LINE

Stage I provides a front line defense against leakage. The blow-out proof stem shoulder has a 45 degree bell shaped slope. The bell shaped design offers more sealing surface, effectively blocking all leak paths during rotation. The wedging action of the portion of the stem is far superior to the common small flat stem shoulder design.

STAGE II - GUIDE-SEAL

The O-ring originated early in valve design and has been a proven performer in high cycle applications. Its basic function reduces the potential of machining imperfections and provide a low torque flexible seal. This center guide also helps to maintain a perfect stem alignment, by eliminating side loading stress which can cause stem leaks.

Standard offered with Viton material, consult factory if other material is required.

STAGE III - LIVE-SEAL

Live-Seal is considered the intellectual component and the workhorse of Flo-Tite's Van Guard stem sealing system. Working in unison with stages I and II, stage III calls upon the use of V-Ring packing sets which expands side ways as it is compressed and pressurized blocking all air pockets. The Van-Guard stem system is energized by belleville washers which continueously adjusts packing compression to componsate for wear, pressure or temperature fluctuations.

Whether your service involves volatile organic compounds, volatile hazardous chemicals, or air pollutants. Flo-Tite's ball valves are by design dependable, long lasting and fully maintainable. Flo-Tite has various valve solutions and designs that provides end users freedom of choice for the toughest requirements imposed by the industry and by international standards.

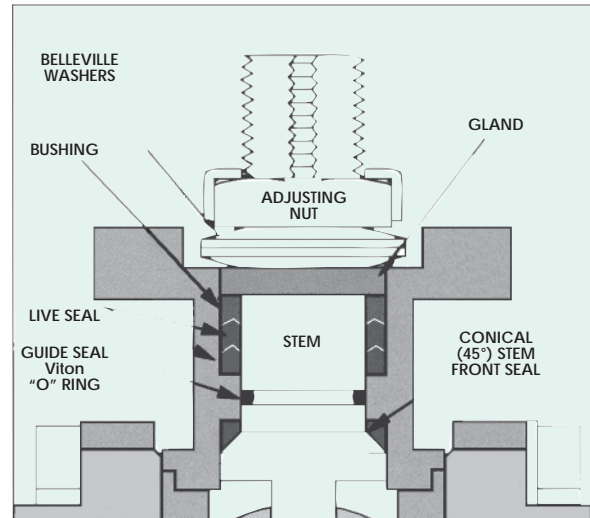

ADVANTAGES OF CAP SCREW BOLTING



Solid construction with double the number of body bolts threaded to more than half their length, results in a reduction in linear thermal expansion of the bolts and a dramatic decrease in the likelihood of leakage from the body. In addition, spring washers can be used to compensate for thermal contractions of valve parts during severe operation.

MATERIAL IDENTIFICATION



Flo-Tites marking system follows MSS SP-25-1998 guidelines. In addition to the cast body information, we have decided to add metal name plates that identify all valve soft parts. Valve users worldwide will be able to contact Flo-Tite quickly for any installation or service requirements as the company website address will be on all valves.

WELD IN-PLACE

Super-Teks high temperature seat capabilities allow weld end ball valves to be welded to the piping system without disassembly following special welding procedures. This unique advantage results in ease of installation and cost savings while insuring full integrity of the factory assembled and tested valve.