

The 337F Series Sanitary Ball Valve

The 337F series ball valve incorporates several innovative design features for improved process performance. The valve's uniform bore diameter improves flow characteristics and eliminates pooling of potential contaminants. Roll burnishing and polishing all 316L stainless steel internal surfaces reduces surface porosity and improves finish. The ISO 5211 mounting pad allows for direct mounting of most actuators.

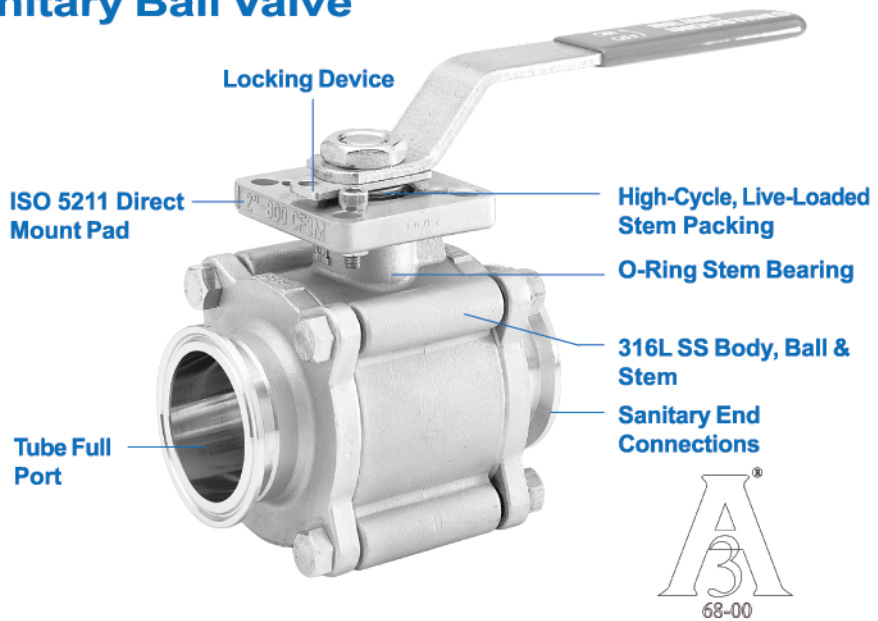

Standard Features and Benefits

- **Tube Full Port Design**
True tube full port construction eliminates pooling of process media and improves flow characteristics for greater efficiency
- **Made of Corrosion-Resistant 316L SS (A351 Gr. CF3M)**
One valve can be used for many service conditions
- **ISO 5211 Direct Mount Pad**
No bracket or drive coupling needed for automation
Improves actuator positioning and prevents side loading
Eliminates exposed moving parts for safer work environment
- **High-Cycle, Live-Loaded Stem Packing**
Ensures tight seal
Extends service life
- **O-Ring Stem Bearing**
Maintains stem alignment
Reduces packing side loading and wear
Enhances stem seal
- **Blow-Out-Proof Stem**
Stem is bottom loaded to prevent removal when valve is in service
- **3-Piece Swing-in-Place Construction**
Easy to repair in service line
- **Locking Device**
Enables plant personnel to secure valve in open or closed position when manually operated
- **Investment Cast**
Improves dimensional control and reduces porosity
- **Internal Surfaces Roll Burnished Prior To Final Polish**
Reduces surface porosity
Improves surface finish
- **BPE compliant extended tube ends**
- **20 Ra Internal Surface Finish**

Options

- Clamp, tube butt weld, extended tube butt weld ends
- Polish and Electro-polish to customer's specification
- Cavity Filled
- CIP connections
- 3A Approved

337F Pressure / Temperature Chart
(TFM Seats)

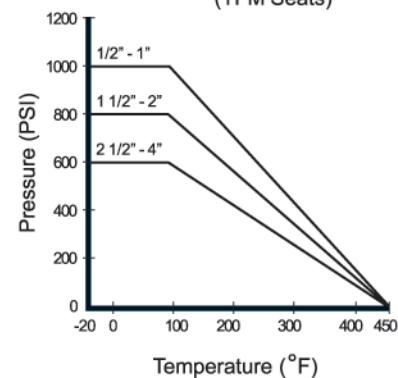

Operating Conditions

- Temperature Range (TFM Seats): -20°F - 450°F
- Maximum Pressure (TFM Seats): 1000 PSI (1/2" - 1"), 800 PSI (1 1/2" - 2"), 600 PSI (2 1/2" - 4")

Specifications

- Valves inspected and tested to API 598 and meet ANSI/FCI70-2 Class VI and MSS SP-61 seat leakage requirements
- All materials comply with applicable ASTM material specifications, and FDA, USDA and ASME BPE material requirements
- All soft wetted parts comply with FDA CFR Title 21 Part 177
- Material test reports available upon request
- Certified to 3A 68-00 with cavity filled seats and clamp ends

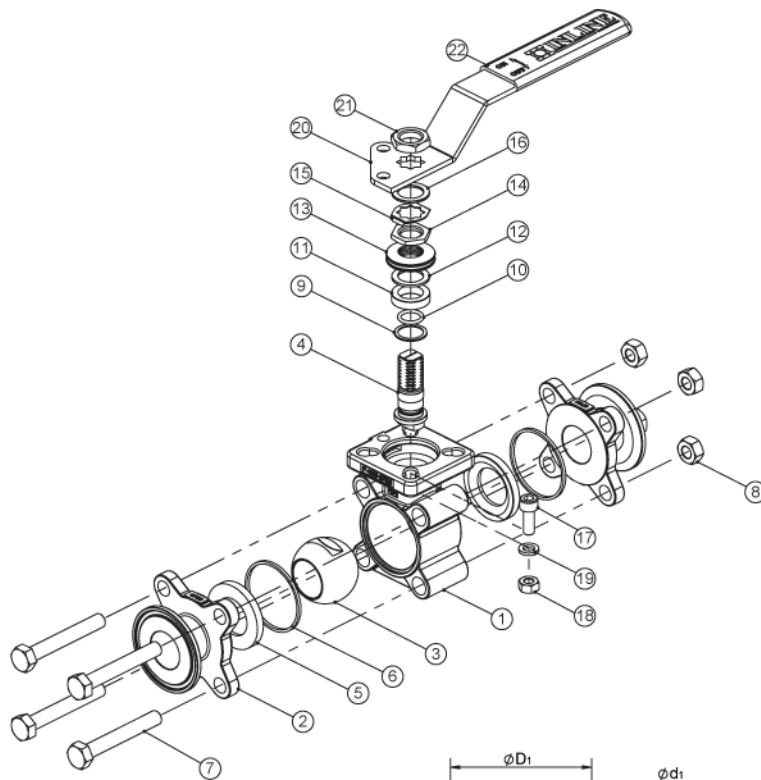

Stem Option

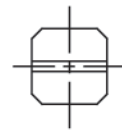

Type 1
Standard

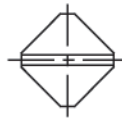

Type 2



Locking
Device

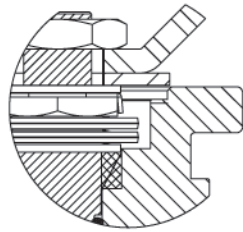

Detail C

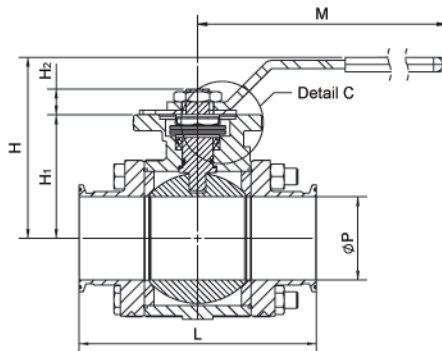
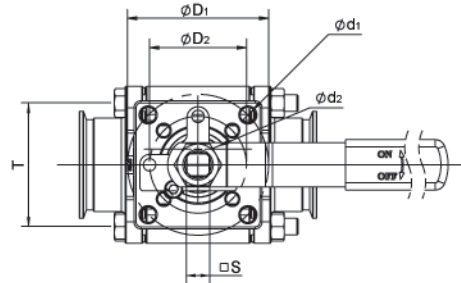

Valve Components			
#	Part Name	Material	Qty.
1	Body	A351 Gr. CF3M	1
2	End Cap	A351 Gr. CF3M	2
3	Ball	316L SS	1
4	Stem	316L SS	1
5	Seat	TFM	2
6	Body Seal	TFM	2
7	Body Bolt	304SS	4 ¹
8	Body Nut	304SS	4 ¹
9	Thrust Washer	PEEK	1
10	Stem O-Ring	Viton 90	1
11	Stem Packing Set	TFM	1
12	Packing Gland	304SS	1
13	Belleville Washer	301SS	4
14	Gland Nut	304SS	1
15	Gland Nut Lock Washer	304SS	1
16	Stem Spacer	304SS	1
17	Stop Pin	304SS	1
18	Stop Pin Nut	304SS	1
19	Split Washer	301SS	1
20	Handle	304SS	1
21	Handle Nut	304SS	1
22	Handle Cover	Vinyl	1

¹ 4" Valve: 6 Nuts and Bolts

Dimensions (Inches)														
Size	L	M	P	H	H ₁	H ₂	D ₁	D ₂	d ₁	d ₂	S	T	ISO 5211 Pattern	Wt. (lbs)
1/2	3.50	5.41	0.38	2.76	1.54	0.35	1.65	1.42	0.22	0.22	0.35	1.23	F03 / F04*	1.60
3/4	3.50	5.41	0.62	2.76	1.54	0.35	1.65	1.42	0.22	0.22	0.35	1.23	F03 / F04*	1.60
1	3.50	6.37	0.87	3.09	1.88	0.41	1.97	1.65	0.28	0.24	0.43	1.71	F04 / F05*	3.06
1 1/2	4.50	8.02	1.37	4.02	2.39	0.58	2.76	1.97	0.35	0.28	0.55	2.22	F05 / F07*	5.76
2	5.00	8.02	1.87	4.38	2.74	0.58	2.76	1.97	0.35	0.28	0.55	2.79	F05 / F07*	8.63
2 1/2	6.75	11.82	2.37	5.15	3.52	0.74	4.01	2.76	0.44	0.35	0.67	3.52	F07 / F10*	18.85
3	7.76	11.82	2.87	5.53	3.89	0.72	4.01	2.76	0.44	0.35	0.67	3.52	F07 / F10*	29.61
4	9.51	13.59	3.84	7.19	5.16	0.94	4.92	4.02	0.54	0.45	0.87	7.99	F10 / F12*	53.27

* Direct mount with stem adapter bushing



Oxygen Cleaning & Electropolishing



Sanitary Products



Automation Systems

337F Ordering Information

Example: 2" Full Port Direct Mount Sanitary Ball Valve, 316L SS Body and Trim, TFM Seats and Seals, Clamp Ends, 25 Ra Max Mechanical Polish (ID)

Valve Series	Valve Size	Body Material	End Material	Ball Material	Stem Material	Seat	Seal	End Connections	Port	Ball Config.	Surface Finish	Special Config.
337F - Full Port	2" 1/4" 3" 3/8" 5 1/2" 7 3/4" A 1" C 1 1/2" D 2" E 2 1/2" F 3" G 4"	3 - A351 Gr. CF3M (316L)	3 - A351 Gr. CF3M (316L) 6 - A351 Gr. CF8M (316)**	3 - A351 Gr. CF3M (316L)	3 - A351 Gr. CF3M (316L)	M - TFM T - PTFE J - TFM Cavity Filled K - PTFE Cavity Filled N - TFM 1-Piece Seat/ Body Seal	M - TFM T - PTFE N - TFM 1-Piece Seat/ Body Seal	C - Clamp O - Tube O.D. Butt Weld E - Extended Tube O.D. Butt Weld K - Tank Bottom R - I-Line L - Long Clamp T - NPT (316) P - Compression (316) A - ANSI 150# (316)	2 - 2 Way	S - Straight Port	None - 25 Ra Max, Mech. Polish SFV1 - 20 Ra Max, Mech. Polish SFV3 - 30 Ra Max, Mech. Polish SFV4 - 15 Ra Max, Electropolish SFV5 - 20 Ra Max, Electropolish SFV6 - 25 Ra Max, Electropolish	00 - None CP - Clean in Place Body

* tube butt weld, extended weld, and compression end only
** For NPT, Compression, and ANSI 150# Only

Due to continuous product development, information may change without notice.



INLINE INDUSTRIES, INC.

9056 Garvey Avenue
Rosemead, CA 91770
Tel: (626) 813-6188
Fax: (626) 813-6186
www.ballvalve.com
info@ballvalve.com

Distributed by: