

109S Firesafe Flanged Ball Valve

1-Piece Standard Port (ANSI 150)
ISO 5211 Mounting Pad



For Automated &
Manual Service

General Chemical
Industrial

Other Corrosion
Resistant Applications

Standard Features and Benefits

- 1 **Firesafe tested to API 607 5th Edition**
- 1 **ISO 5211 Mounting Pad**
Ease of automation
- 1 **Investment Cast**
Improves dimensional control and reduces porosity
- 1 **High-Cycle, Live-Loaded Stem Packing**
Provides constant load on the stem seal and extends service life
- 1 **Blow-Out-Proof Stem**
Stem is bottom loaded to prevent removal when valve is in service
- 1 **Anti-Static Device**
Grounds ball and stem to valve body
- 1 **Standard Seats and Seals Suitable for 150 PSI Saturated Steam**

Options

- 1 **Carbon Steel Construction to NACE MR-01-75**
- 1 **One-Piece Stem Extension**
- 1 **Weld-on Jacket**
- 1 **Upstream Relief Vent Hole**

109S Pressure / Temperature Chart
(ANSI 150 RTFE Seats)

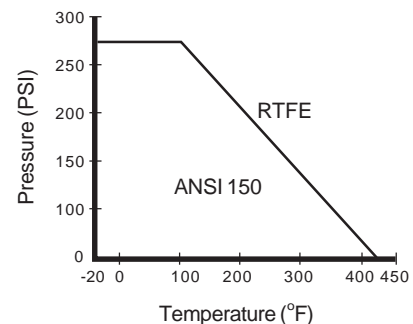

Operating Conditions

- 1 Temperature range (CF):
-20°F ~ 420°F
- 1 Maximum pressure (CF):
ANSI 150: 275 PSI WOG @ 100°F

Specifications

- 1 All valves shell and seat tested to ANSI/ASME B16.34 and API 598
- 1 Length to ANSI B16.10,
Connection to ANSI B16.5
- 1 Firesafe tested to API 607, 5th Edition

Valve Components			
#	Part Name	Material	Qty.
1	Body	A351 Gr. CF8M	1
2	Insert	A351 Gr. CF8M	1
3	Ball	316SS	1
4	Stem	316SS	1
5	Seat	RTFE (15% C.F.)	2
6	Body Seal	PTFE / Graphite	1
7	Thrust Washer	PEEK	1
8	Stem Packing Set	PTFE / Graphite	1
9	Packing Gland	304SS	1
10	Belleville Washer	301SS	2
11	Gland Nut	304SS	1
12	Gland Nut Lock Washer	304SS	1
13	Stop Plate	304SS	1
14*	Handle Nut	304SS	1
15*	Handle	304SS	1
16	Stop Pin	304SS	1
17*	Handle Cover	Vinyl	1

* 6" uses a T-Handle made of carbon steel.

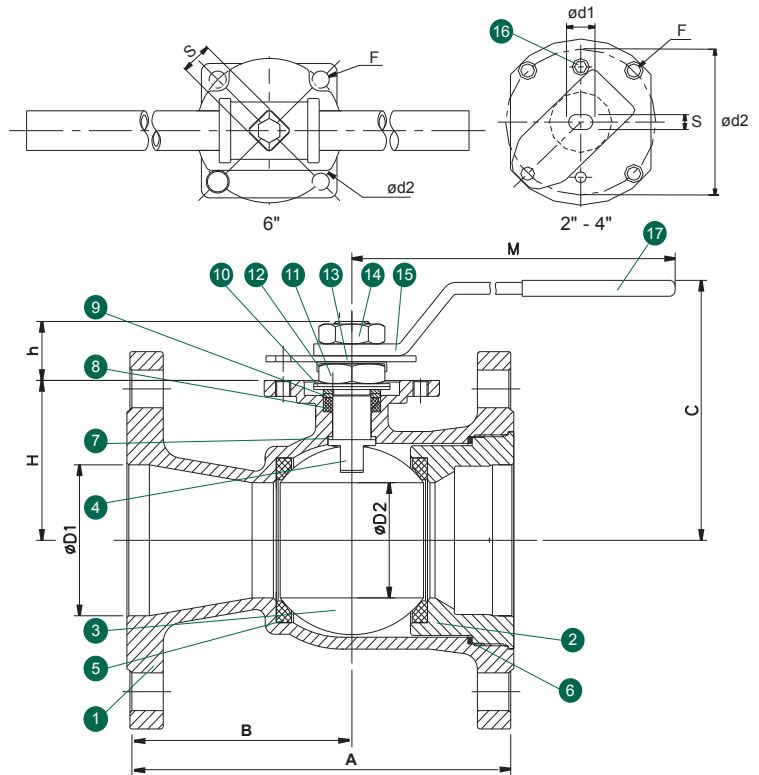

Dimensions (Inches)														
Size	A	B	C	D1	D2	d1	d2	F	M	H	h	S	Weight (lbs)	CV
2"	7.00	2.95	4.00	2.00	1.50	0.70	2.76	M8	10.0	2.20	1.27	0.381	13.0	150
3"	8.00	3.35	5.15	3.00	2.50	0.78	4.02	M10	12.3	3.17	1.30	0.472	31.0	350
4"	9.00	3.75	6.70	4.00	3.00	0.78	4.02	M10	12.3	3.65	1.36	0.472	47.0	700
6"	10.50	4.13	7.10	6.00	4.00	0.87**	4.02	M10	8.25	4.50	1.46	0.866	76.0	1000

** 6" uses a diamond stem. See dimension S.

109S Ordering Information

Example: 2" Standard Port Ball Valve, Actuator Mounting Pad with Lever Handle and Locking Device, 316SS Body and Trim, RTFE (15% C.F.) Seats, Graphite Seals, ANSI 150# Flanged Ends

Valve Series	Valve Size	Body Material	End Material*	Ball Material	Stem Material	Seat	Seal	End Connection	Port	Ball Config.	Misc.
109S - Standard Port	D 2" F 3" G 4" I 6"	6 - A351 Gr. CF8M (316) 2 - A216 Gr. WCB	6 - A351 Gr. CF8M (316) 2 - A216 Gr. WCB	6 - A351 Gr. CF8M (316)	6 - A351 Gr. CF8M (316)	C - RTFE (15% C.F.) T - PTFE	G - Graphite T - PTFE	A - ANSI 150#	2 - 2 Way	S - Straight Port	00 - None J - Weld-on Jacket

Due to continuous product development, information may change without notice.

Note: Firesafe requires graphite packing and body seal.



INLINE INDUSTRIES, INC.

9056 Garvey Avenue
 Rosemead, CA 91770
 Tel: (800) 568-8998
 (626) 813-6188
 Fax: (626) 813-6186
 www.ballvalve.com
 info@ballvalve.com

Distributed by: